

WECKMAN

Installation of roof sheets



	Page
1. Handling	
1.1. Receiving the goods	4
1.2. Work safety	4
1.3. Handling	4
1.4. Storage	5
1.5. Preparations for installing and cutting the sheets.....	5
2. Installation of profiled roof sheets	7
2.1. Dimensioning of sheets.....	8
2.2. Number of sheets	9
2.3. Underlay and ventilation by using lateral battening.....	9
2.4. Ventilation	10
2.4.1. Ventilation by using lateral battening	10
2.4.2. Ventilation under the underlay	10
2.5. Roof battening (lateral and up)	11
2.6. Installation of sheets	12
2.7. Fastening of sheets	13
2.8. Special areas	14
2.8.1.1. Valleys	14
2.8.1.2. Valleys ending at roof pane	15
2.8.2. Thru holes	16
2.8.3. Snow barrier	16
2.9. Sealing	17
2.10. Gable flashing	17
2.11. Ridge capping	17
2.12. Endwall flashing	18
2.13. Eaves flashing	18
3. Installation of corrugated roof sheets	19
3.1. Dimensioning of sheets	20
3.2. Number of sheets	20
3.3. Underlay and ventilation by using vertical battening	20
3.4. Ventilation	20
3.4.1. Ventilation by using lateral battening	20
3.4.2. Ventilation under the underlay	20
3.5. Roof battening (lateral and up)	21
3.6. Installation of sheets	22
3.7. Fastening of sheets	22
3.8. Special areas	23
3.8.1.1 – 3.13. are the same as 2.8.1.1 – 2.8.3.	
4. Maintenance of coated roof sheets	23
5. Renovating old roofs with Weckman products	24

Parts of the roof

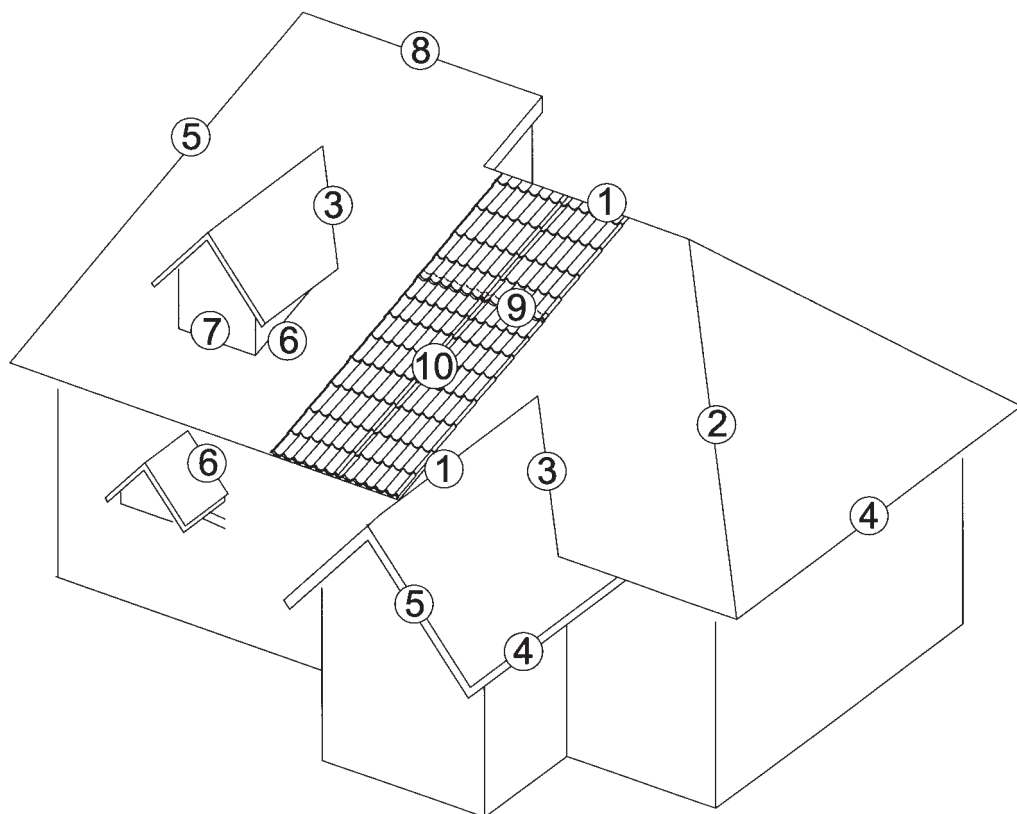

PART:

1. Ridge
2. Hip roof/hip roof valley
3. Valley
4. Lower eave
5. Gable eave
6. Longitudinal hip
7. Transversal hip
8. Top eave
9. Overlapping the sheets
10. Lateral overlapping the sheets

PRODUCT TO BE USED:

- Ridge capping (universal/flat) + ridge filling
- Ridge capping (universal/flat) + hip roof filling
- Valley flashing + valley filling
- Eaves flashing (+ small filling)
- Gable flashing
- End wall flashing
- End wall flashing + profiled filling
- Gable flashing + ridge filling
- Low-angled roofs: use sealing tape
- Low-angled roofs: use sealing tape

Instructions for installing roof sheets

1. Handling

1.1. Receiving the goods

Check that the shipment contains all the products specified in the delivery note. If the goods do not match the delivery note, or if the goods show any transportation damage, **list it on the freight bill**. Describe the damage and the number of the wrong or faulty goods, **and contact your supplier immediately**.

Do not use defective products under any circumstances. Claims must be made within 8 days from the arrival of the goods. The factory does not cover expenses caused by exchange of products when installation was not carried out according to factory instructions.

1.2. Work Safety

Avoid handling the sheets in a strong wind. The edges and corners of the sheets are sharp and rough after cutting. Always use protective gloves and clothing. The sheets are slippery, especially when wet or icy. Always use a lifeline and soft-sole footwear on the roof. Before you move a bundle of sheets, check that it is securely attached to the lifting equipment. Never walk under a bundle of sheets or a single sheet. Always observe local safety regulations.

1.3. Handling

When sheets are unloaded from the transportation vehicle onto the customer's platform, place them on boards spaced max. 1 m apart at a minimum of 20 cm from the ground. (Drawing 1).

Lift the sheets one at a time, **do not pull**, as the sharp edges will damage the coating of the sheet underneath. Handle thin metal sheets carefully as they bend and dent very easily. Long, profiled sheets (tile-patterned sheets) stretch easily. Do not lift them at the ends but hold them on the sides. To remove stains use a neutral detergent.

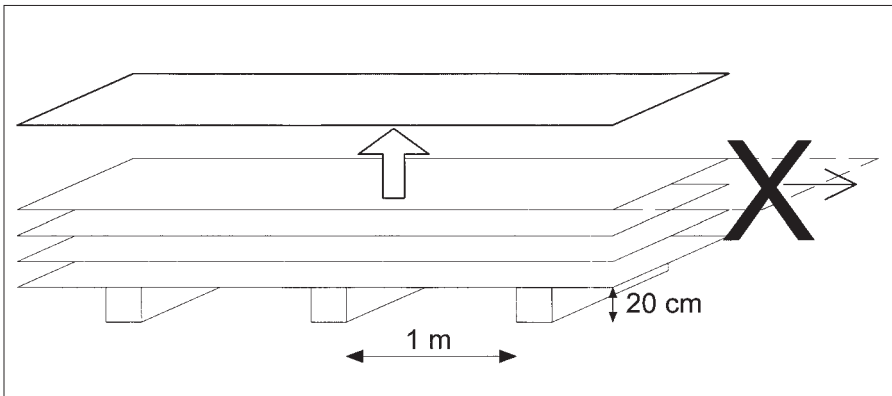

Drawing 1 Handling of sheets

1.4. Storage

Galvanized sheets must not be stored in tight bundles. Protect the sheets and pile them on an incline so that any water can easily run off and evaporate from the sheets.

Coated sheets can be stored unpacked or in the transportation package for max. two weeks under normal conditions. If they are stored longer, follow the instructions for storing galvanized sheets. Windy weather may cause a hazard, so place a weight on the sheets or tie them up securely.

1.5. Installing and cutting the sheets

Before installation, check the cross-measure of the roof pane (Drawing 2) or of any other geometric design.

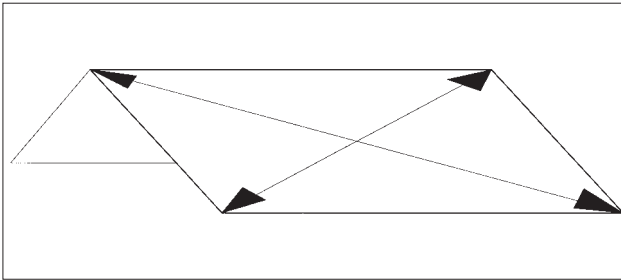

Drawing 2 Roof pane cross-measure

Before installing the sheets, fasten all additional battens and supports needed for roof safety products (ladders, roof bridges, snow barriers) and thru holes (trap doors). Lift the sheets onto the roof along strong planks extending from the lower eaves to the ground (Drawing 3).

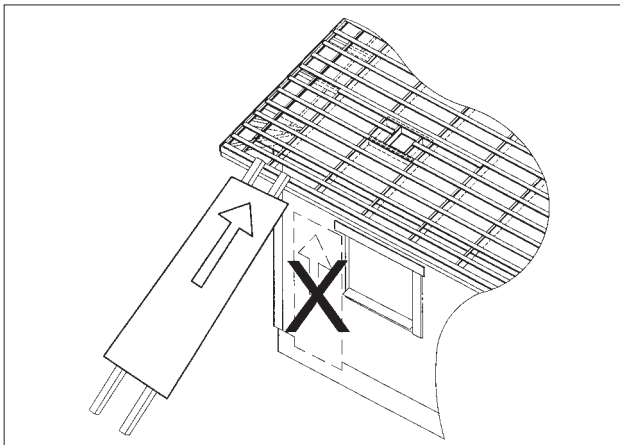

Drawing 3 Lifting the sheets onto the roof

Use a hand circular saw (be careful to use a steel-cutting blade), nibbler, a jig saw, or plate shears. **Do not use a disc cutter to cut the sheets.** Always keep a distance of 10 metres from coated sheets, because the heat and spatters will burn the coating. Protect the cut areas, because hot metal shavings will damage the coating. Clean off all metal strips and shavings from the roof as rusting bits of metal and pop rivet stems will eventually damage the roof. We would recommend touching up of all cut edges, sheet ends at the eaves or any scratches with a special touch-up paint after the installation.

Always use high enough scaffolding and good, strong safety rails. Keep the right working distance.

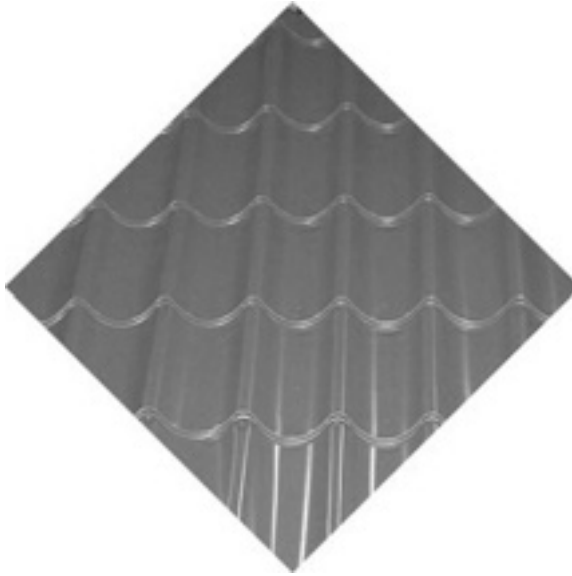

2. Installation of profiled roof sheets

(Type 1, Type 2, Type 3)

2.1. Dimensioning of sheets

The usual sheet length is = rafter length + facing board(s). When profiled roof sheets (= tile-patterned sheets) are used, note certain special requirements. If sheets of different lengths are installed on the roof pane (terrace roof), the length C of the eaves projection must be a multiplex of the length of the tile pattern (Type 2 and 3) = 350 mm, Type 1 = 400 mm). Otherwise the tile design will not match (Drawing 4).

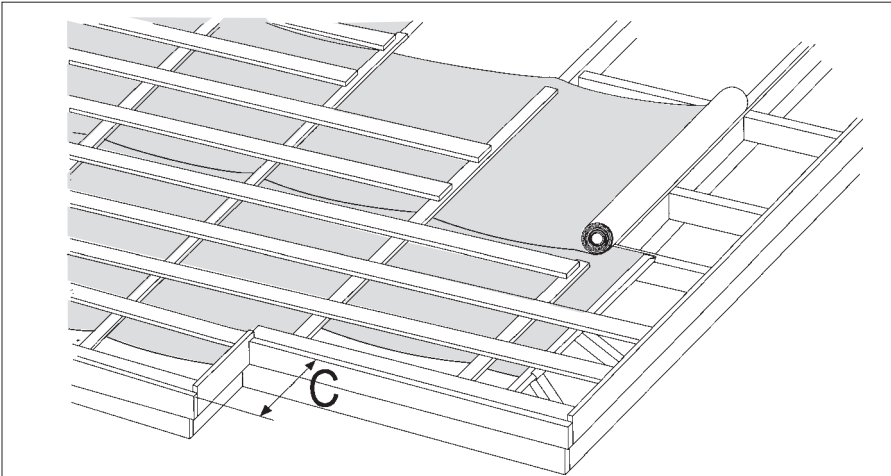

Drawing 4 Construction drawing for installation of underlay

When the projection cannot be made as a multiplex of the tile-pattern, the roof pane can be made of two sheets. Then the length of the ‘tile’ at the overlap will be a different length from the rest. The multiplex-quality of the tile-pattern and the sheet lengths must also be checked at valleys ending at the roof pane.

The recommended maximum sheet lengths are shown in Table 1.

	Effective width mm	Total width mm	Recommended maximum length mm	Minimum length mm
Type 1	1025	1110	6500	530
Type 2	1050	1130	6500	450
Type 3	1120	1180	6500	450

Table 1

If the roof pane is made of two or more sheets, the overlap must be 130 mm. Always use a batten under an overlap.

Certain sheet lengths of Type 1 have an additional transverse folding at the ridge end of the sheet to help the installation by keeping the edge in shape. Remember this when you order Type 1 sheets of different lengths for the same roof pane.

2.2. Number of sheets

Calculate the number of sheets by dividing the ridge length by the effective width of the profile and then round off the number to a full figure up (multiply by two if you work on two panes). The effective width of the last sheet to be installed is the total width. The (nominal) widths of the patterned sheets are shown in Table 1.

If profiled sheets are installed on a hip roof, the leftover sheets cannot be used on the other side of the roof. However, crosswise installation is all right with corrugated sheets. Angle cuts of hip and valleyed roofs must be made at the construction site.

2.3. Underlay and ventilation by using lateral battening

Put the underlay under the sheets to stop condensing water from getting into the structures. Roll the underlay horizontally across the roof starting from the lower eaves. Staple the underlay to the roof trusses. The underlay must overlap by at least 150 mm. Do not stretch the underlay between the trusses, but leave it sagging abt. 20 – 30 mm. When you reach the ridge or hip, place abt. 150 mm of the underlay on both sides of the ridge. (Also see Section 2.4) At the lower eaves, place the underlay far enough to stop condensing water from getting into the wall structures, leaving room for ventilation above the underlay (Drawing 5). Bring the underlay at least 200 mm past the outermost part of the wall structure when you reach the gable eaves (Drawing 6).

Nail down a battening on top of the underlay (min. 32 x 50 mm, Drawing 4).

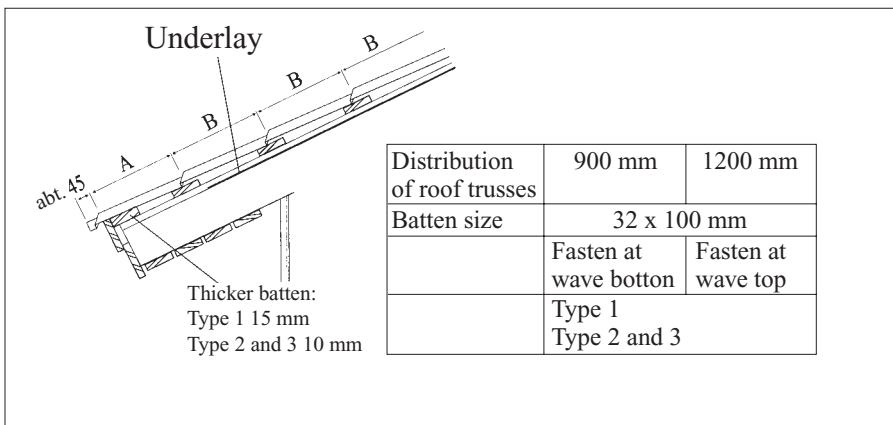

Drawing 5 Roof board dimensioning

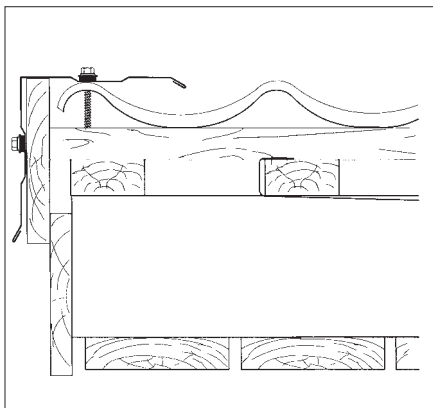

Drawing 6 Gable eaves

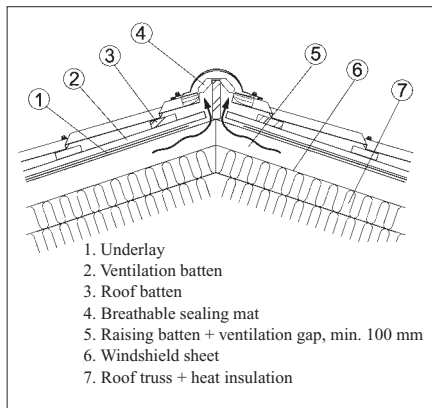

Drawing 7 Breathable sealing mat

2.4. Ventilation

2.4.1. Ventilation by using lateral battening

Nail down a batten to the trusses on top of the underlay. Construct the eaves so that the ventilation air can flow in the space between the underlay and roof sheets. At the ridge, the ventilation air is directed out through ventilation pieces. If the ridge is short (max. 10 m), the air is made to flow out through the ends of the ridge capping.

In hip roofs, the ventilation air will flow out through ventilation pieces at the hips. A pentroof and a wall can be joined as shown in Drawing 9.

2.4.2. Ventilation under the underlay

Eaves structure must let ventilation air flow freely into the ventilation space under the underlay. The air will flow out through gable vents at the gable wall.

If the heat insulation is laid down in the same direction as the pane reaching all the way to the ridge, the underlay must be left open on top (abt. 100 mm). To stop water from getting into the structures, install a breathable ridge sealing mat (Drawing 7) or use a structure as shown in Drawing 8.

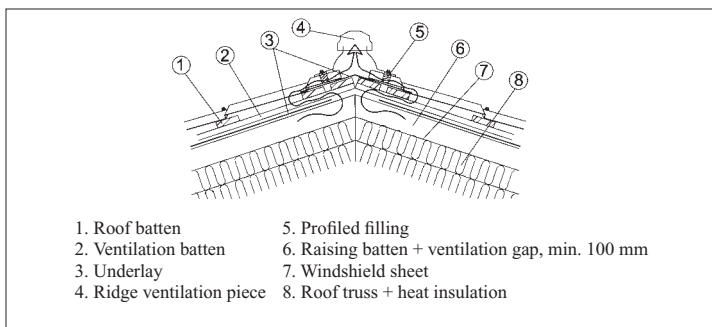

Drawing 8 Ridge ventilation piece

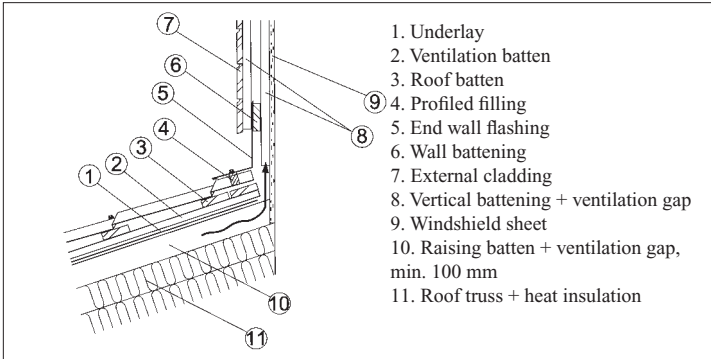

Drawing 9 Roof and wall joint

There the air is let out through ventilation pieces at the ridge. This ventilation system is also suitable for hip roofs and individual fire sections of terraced house roofs. The free ventilation space under the underlay must be at least 100 mm throughout the roof.

2.5. Roof battening

To decide the thickness of the roof battens, measure the right length for the fasteners, which is the wave height of the sheet and the thickness of battens. The battens must be min. 32 x 100 mm. (Drawing 5)

The lowest batten must be thicker than the rest, about 10 mm thicker for Type 2 and Type 3, and about 15 mm thicker for Type 1. Nail the battens diagonally into the roof truss by using 2.8 x 75 mm hot galvanized nails (2 nails per intersection).

Be careful not to block the ridge with battens, but leave enough space to ensure efficient ventilation (Drawing 10).

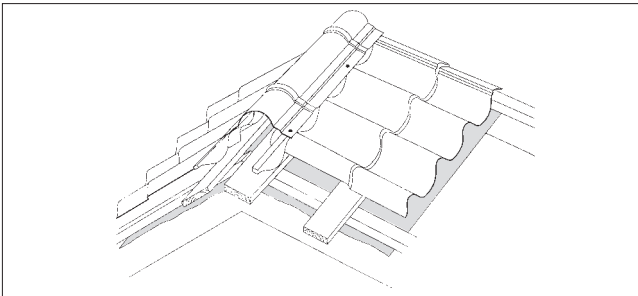

Drawing 10 Ridge structure

Install an extra batten above and below the opening at thru hole locations (trap doors, ventilation air pipes and chimneys). If needed, support the cut ends of battens at the opening by placing support battens under the ends. (Drawing 11)

When the roof pane is made of two or more sheets, there must be a batten under each overlapping extension.

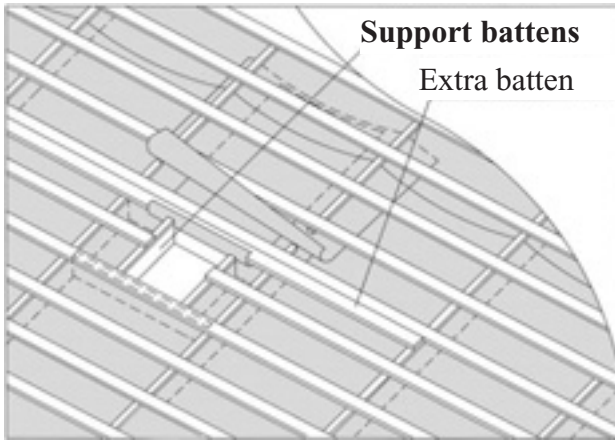

Drawing 11 Thru hole supports

2.6. Installation of sheets

During installation, be careful when you walk on the sheets. They do not stand a heavy load! When walking on profiled sheets, always place your steps on the roof boards, so that your foot rests at the bottom of a wave or on the ridge of several waves. Installation can be made from right to left, or the other way round. When installing Type 2 or 3 sheets from right to left, the edge of the sheet must be pushed under the previous sheet. This makes the work easier, because now the new sheet will rest on the transverse foldings of the previous sheet, which keeps the new sheet from sliding down. **Leave the capillary groove at the bottom.**

Install the sheets in line with the lower eaves, not with the gable eaves. The sheet must go about 45 mm past the eaves. Fasten the first sheet with one screw from its upper edge (centre) to the batten at the bottom of a wave. Overlap the next sheet on the first sheet at the lower edge. Check carefully that the transverse sheet foldings fit tightly. Fasten the sheets just under the wave, starting from the sheet's lower edge and then work up. Use 4.8 x 28 mm drilling screws. After the first 3 – 4 sheets, set them in line with the lower eaves. Use an alignment wire or board to assist this. Fasten the sheets to the battening and continue by fastening each sheet first to the previous sheet, then to the battening.

If there are any extension overlaps in the roof panel, follow the installation order in Drawing 12.

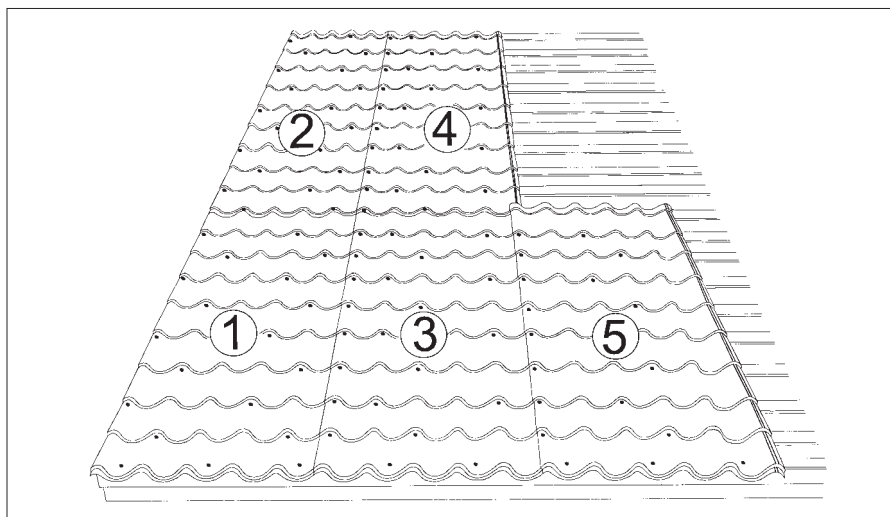

Drawing 12 Installation order and spacing between screws

2.7. Fastening of sheets

We recommend fastening the sheets with screws on top of the waves (Drawing 13). The usual screw size is 4.8 x 50 or 4.8 x 65 mm. Use 4.8 x 28 mm size screws for bottom-of-the-wave fastening at the lower eaves and at all overlapping sections (Drawing 14). 4.8 x 28 mm size screws can also be used to install sheets at the bottom of the wave. The screws must have EPDM rubber gaskets. We recommend screws because they hold almost double the strength of nails as they screw in between the timber grains. (A nail presses the grains downwards and when the timber dries out, the grains straighten and lift the nail.)

Do not overtighten long screws too much. Use a drilling machine with adjustable torque.

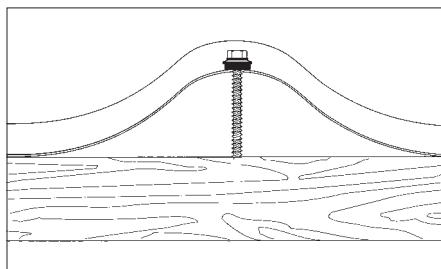

Drawing 13 Fastening to roof board

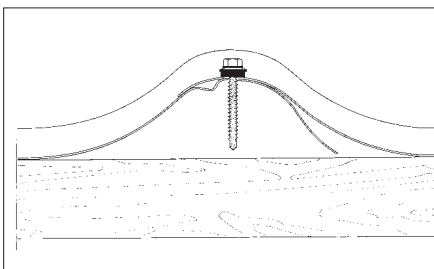

Drawing 14 Lateral overlap

Distribution of screws (Drawing 12):

- Lower eaves: Into the battening at the bottom of every two waves
- Lateral overlaps: Below each transverse folding into another sheet
- Gable eaves: Below every second transverse folding into the battening
- Extension overlap: On top of every second wave ridge, below transverse folding into the battening
- Ridge of hip roof: At the bottom of every second wave into the battening
- Need of screws: 6 pcs/m²

2.8. Special areas 2.8.

2.8.1.1. Valleys

Drawing 15 shows a valley with a V-shaped valley flashing. First install a full-width strip of underlay all the way in line with the valley and fasten the underlay to the trusses. Then cover the rest of the underlay as instructed in Section 2.3.

Fasten the ventilation battens (32 x 50 mm) for the whole rafter length, starting at abt. 50 mm from the bottom of the valley. Fasten the baseboards for the whole length of valley flashing. Use timber of the same thickness as for battens, leaving a space of 50 mm at the bottom of the valley.

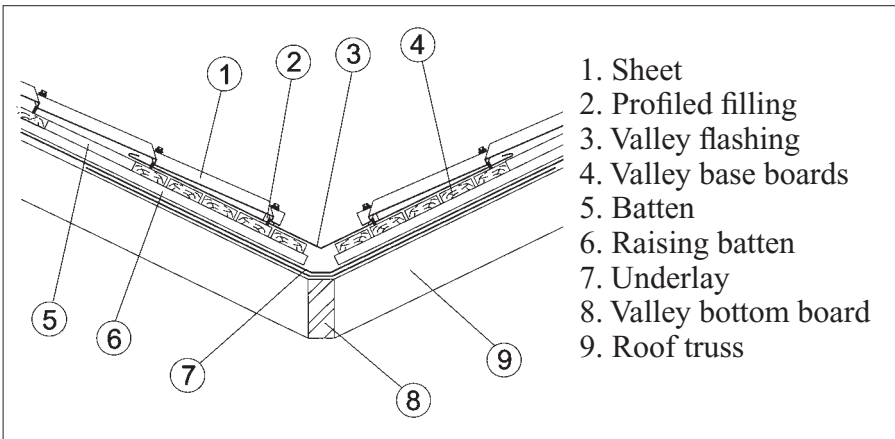

Drawing 15 Valley

Fasten the battens on top of ventilation battens with a screw distribution recommended for that type of sheet. Continue all the way to the valley baseboards. Screw the valley flashing to the baseboards in places to be covered with sheets. Start from the lower edge of the roof. Overlap the valley flashing joints by at least 200 mm and use an elastic, climate-proof sealing compound between the overlapping flashings.

Fasten the sheets to the battening and place a valley filling between the sheets and the valley flashing. Use a drilling screw or a sealing compound to make sure that the filling will stay in place. The free width of the valley (the horizontal distance between the opposite sheets) is abt. 200 mm.

2.8.1.2. Valleys ending at roof pane

The principle of a valley ending at the roof pane is shown in Drawing 16.

The construction of this type of valley is similar to the valley explained in Section 2.8.1.1. Only the construction process is different:



1. Place a sheet on the eave extending vertically at least 400 mm above the end of the valley.

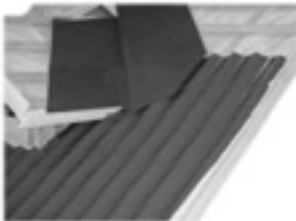

2. Screw a piece of valley flashing (shaped to match the lower part of the side roof) to the baseboards in places to be covered with sheet.

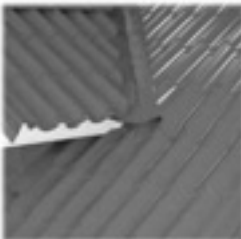

3. Place a sheet profile (shaped to match the valley) and side-roof sheets on the ridge.

Drawing 16 Valley ending at roof pane

2.8.2 Thru holes

We recommend that all thru holes be made as close to the ridge's upper edge as possible.

All roof battens ending at trap doors, ventilation air pipes and chimneys must be supported with extra battens. If necessary, also additional battens must be used (Drawing 11). All joints must be sealed carefully. The trap door and ventilation air pipe must overlap at least as far as the overlapping of sheets.

Thru hole elements (sewage ventilation pipe and air-conditioning pipe) come with an underlay sealing flange, EPDM rubber sealing flange and a base plate (see instructions in the package). Air-conditioning piping and devices must be supported to the framework of roof, not to thru hole elements. Heavy masses of snow must be removed from above the thru holes. If thru holes are placed more than one meter below the ridge, we recommend installation of a snow barrier above such holes.

2.8.3 Snow barrier

We recommend the use of a snow barrier on roofs near or above pedestrian traffic zones or plants you may wish to protect. A snow barrier is placed on the roof where piling snow will rest on a load-bearing wall. Before the installation of sheets, fasten horizontal battens (50 x 100 mm) underneath the snow barrier foot pieces. Fasten the snow barrier foot pieces (sets of 4) at the wave bottom following the transverse folding line. Place a sealing strip (3 x 30 mm) between the base plate and the sheet using 8 mm deck screws or bolts and nuts to fasten it. Push the oval tubes (sets of 2) in place and fasten 8 x 35 mm bolts at the holes at tube ends to prevent sliding. (Drawing 17)

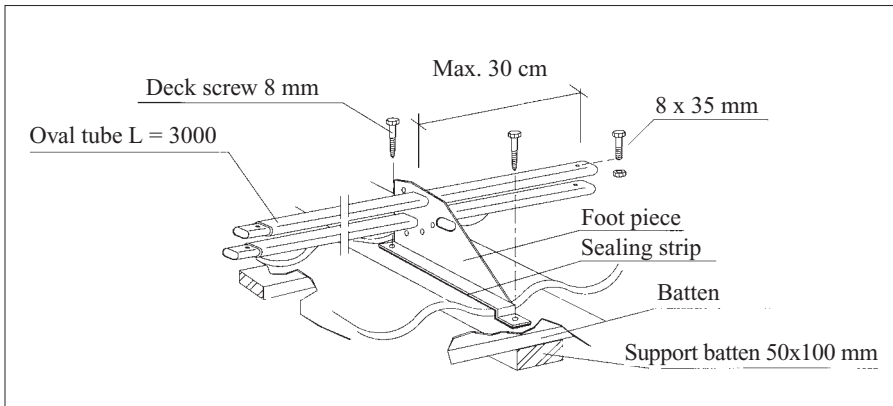

Drawing 17 Snow barrier fastening

2.9 Sealing

The min. roof inclination for profiled roof sheets is 1:4 (Drawing 18). For corrugated sheets it is 1:7. Weckman does not guarantee a proper functioning of profiled roof sheeting if the roof's inclination is any less. If profiled roof sheets are installed on a roof with inclination ratio < 1:4 and for corrugated sheet < 1:7 we recommend sealing of the lateral overlaps.

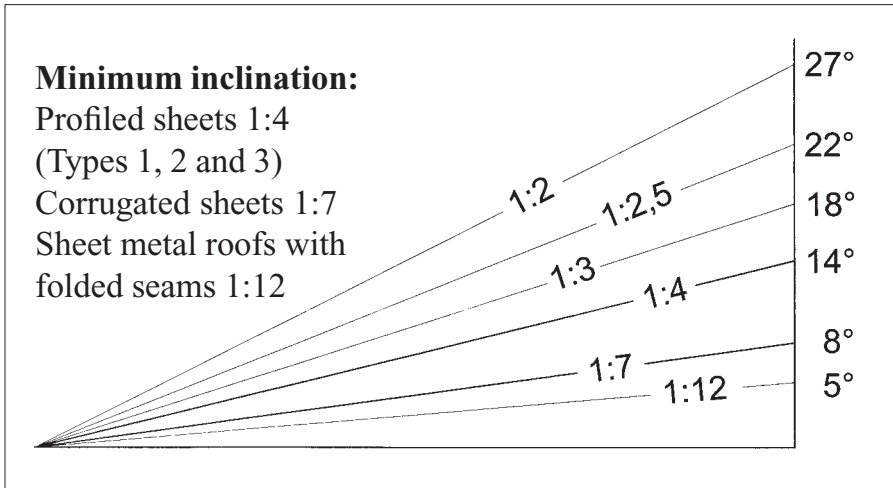

Drawing 18 Minimum inclination

2.10. Gable flashing

Use drilling screws to fasten the gable flashing from its side to the gable board and from the top to the sheet at the wave ridge. (Drawing 6). Max. spacing between screws is 800 mm. The flashings must overlap by abt. 100 mm.

2.11. Ridge capping

Connect 2 – 5 ridge cappings from their lower edge by using 4.8 x 28 mm drilling screws, then set them in line with the ridge. The overlap of profiled ridge cappings must be 130 mm (stiffeners aligned) and the overlap of flat ridge cappings at least 100 mm. Place a ridge filling between the ridge capping and sheets. (Drawing 10) Screw the ridge capping to the sheet through the filling at every two wave tops. If the side roof ridge coincides with the main roof, cut the end of ridge capping to match the inclination of main roof. Make it go as far under the main roof sheeting as possible.

Profiled ridge cappings can also be installed with a ridge sealing mat. Before installing the sealing mat, nail or screw a wooden flash board horizontally at the ridge of the roof trusses. Leave the upper edge of the flash board above the sheets. Roll the ridge sealing mat on top of the flash board, keep the centre of the strip on the board. Clean and dry the upper edges of sheets. Then staple the sealing mat to the flash board by following the centre line. Remove the paper from the adhesive surfaces and press the mat tightly in place against the sheets by following their shapes.

End piece, Y- and T- pieces and hip pieces are available for universal ridge cappings. They are screwed to the ridge capping from their lower edge.

2.12. End wall flashing

Bend the end wall flashing for the horizontal joints of roof and wall to match the roof's inclination. Screw it to the sheet at every two wave tops. For corrugated sheets, use 400 mm spacing. Place a profiled filling between the end wall flashing and the sheet. Leave the upper edge of end wall flashing under the wall cladding (in rock walls, fasten the upper edge to a groove cut in the wall and finish with a sealing compound). Check the proper ventilation of roof and wall structures (Drawing 9).

Fasten the end wall flashing for upward joints of the roof and wall at every second transverse folding on the roof sheets. For corrugated sheets, use 400 mm spacing. Make the end wall flashings overlap by at least 100 mm and use a sealing compound.

2.13. Eaves flashing

Eaves flashing is used at the lower eaves to drain rain water into the gutters and to keep the facing boards from getting wet. Fasten the eaves flashing to the lowest batten before fastening the sheets. Use galvanized flat head nails. The overlap must be abt. 50 mm. A profiled filling can be used between the eaves flashing and the sheets. This will reduce problems caused by birds. (Also see Section 2.4).

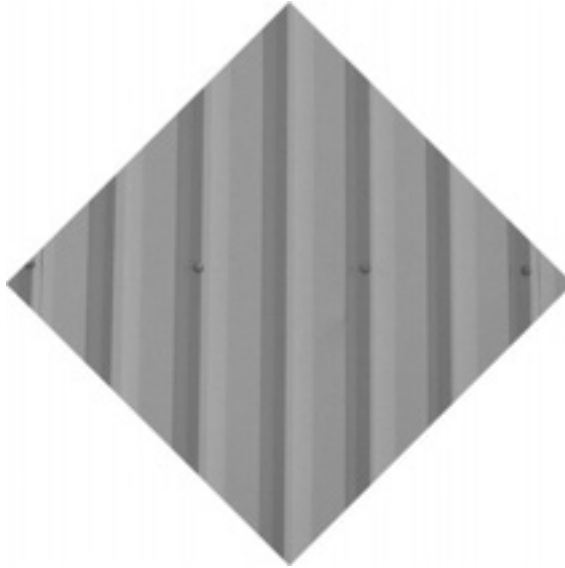

3. Installation of corrugated roof sheeting

(W-1, W-2, W-20 and W-45)

3.1 Dimensioning of sheets

The usual length of a sheet is = rafter length + facing board. The sheet length is important when dimensioning the sheets at valleys ending at the roof pane. (Drawing 16)

The recommended max. lengths for corrugated sheets are shown in Table 2. If the roof pane is made of two or more sheets, the overlap must be at least 200 mm. A sealing strip must be used at extension overlaps. Always use a batten underneath an overlap.

	Effective Width mm	Total Width mm	Recommended max. length mm	Min. length mm
W-1/1064	1064	1120	8000	400
W-2/1150	1150	1180	6000	400
W-20R/1100	1100	1135	8000	400
W-20/990	990	1030	8000	400
W-45ER/1000	1000	1050	10000	400
W-45R/900	900	960	10000	400

Table 2 Corrugated sheet measurements

3.2 Number of sheets

Calculate the number of sheets needed by dividing the ridge length by the effective width of the sheet design and round off the number to a full figure up (multiply by two if you work on two panes). The effective width of the last installed sheet will be the total width. The (nominal) widths of corrugated sheets are shown in Table 2.

On hip roofs, the ‘waste strips’ can be used crosswise on the other side of the roof. Note that the capillary groove will now be at the opposite end. Angle cuts of hip and valleyed roofs must be made at the construction site.

3.3. Underlay and ventilation by using lateral battening. See instructions at 2.3.

3.4. Ventilation

3.4.1. Ventilation by using lateral battening. See instructions at 2.4.1.

3.4.2. Ventilation under the underlay. See instructions at 2.4.2.

3.5.Roof battening

The thickness and distribution of the roof boards depends on the sheets' load bearing capacity, load and roof inclination. The roof boards must be min. 22 x 100 mm. Timber sizes and distribution for corrugated roof sheets are given in Table 3.

If safety products (roof bridge, snow barrier) are to be installed on the roof, we recommend the use of roof battens of min. 32 x 100 mm timber to ensure safe fastening. Nail the roof battens diagonally to roof truss with 2.8 x 75 mm hot galvanized nails (2 nails/intersection).

Be careful not to block the ridge with battens but leave enough space to ensure efficient ventilation.(Drawing 10) If needed, install an extra batten at thru hole locations (trap doors, ventilation air pipes, chimneys) above and below the opening. Support the cut ends at the opening by placing support battens underneath the ends (Drawing 11).

When the roof pane is made of two or more corrugated sheets, there must be a roof board under each overlap.

Profile	Roof truss distribution	Roof batten	Inclination		
			1:3 or less	1:1.5	1:1
W-2/1150	900 mm	22x100 mm	300	400	600
	1200 mm	32x100 mm	300	400	600
	1200 mm	50x100 mm	300	400	600
Profiles	Roof batten	Inclination			
		1:3 or less	1:1.5	1:1	
W-1/1064 W-20 W-45	900 mm	22x100 mm	300	400	600
	900 mm	32x100 mm	400	600	900
	900 mm	38x100 mm	400	900	1200
	1200 mm	38x100 mm	400	600	900
	1200 mm	50x100 mm	750	900	1200

Table 3 Directive batten distribution

3.6 Installation of sheets

When installing corrugated sheets, walk carefully on the sheets because they do not stand a heavy load! Always place your steps on the roof boards, so that your foot rests at the bottom of a wave or on the ridge of several waves.

Installation can be made from right to left, or the other way round.

The capillary groove must always be left **at the bottom**, whether it is on the right or left side.

Install the sheet profiles in line with the **lower eaves**, not with gable eaves. The sheet must extend abt. 45 mm past the eaves. Fasten the first sheet from its upper edge (centre) with one screw to the roof board at the wave bottom. Overlap the next sheet at the lower part of its vertical edge on the first sheet. Attach the sheets to each other at wave top with 4.8 x 28 mm screws, with abt. 500 mm space between screws (300 mm, if a sealing band is used).

After 3 – 4 sheets have been installed, set them in line with the lower eaves. Use an alignment wire or board to assist this.

Fasten the sheets to roof boards and continue installation by first fastening each sheet to the previous sheet, then to the battening.

If you have an odd number of sheets, and you are cladding a ridged roof with two panes, one of the sheets must be cut in two. Start the installation of the second pane by using the other half of the split sheet.

3.7. Fastening of sheets

We recommend fastening the sheets with drilling screws on top of the waves (W-2/1150, W-1/1064, W-20/990 and W-20R/1100). The usual screw size is 4.8 x 50. W-45R/900 and W-45ER/1000 are fastened to battening at the wave bottom. Use 4.8 x 28 mm size drilling screws for bottom-of-the-wave fastening at the lower eaves and at all overlapping sections and for fastening the flashings. The screws must have EPDM rubber gaskets and be especially designed for roofing purposes. We recommend screws because they hold almost double the strength of nails as they screw in between the timber grains. (A nail presses the grains downwards and when the timber dries up, the grains straighten and lift the nail.)

Do not overtighten long screws, or the sheet will dent under the screw. Use a drilling machine with adjustable torque.

Distribution of screws (Drawing 12):

- | | |
|---------------------|---|
| - Lower eaves | max. 400 mm space into batten/purlin |
| - Overlaps | max. 500 mm space or max. 300 mm space with a sealing band |
| - Gable eaves | max. 500 mm space into batten/purlin, or into every batten where distribution is over 500 mm |
| - Extension overlap | max. 400 mm space at the wave ridge (W-1, W-2, W-20), and max. 400 mm space at the wave bottom (W-45R) into batten/purlin |
| - Ridge of hip roof | max. 400 mm space at the wave bottom into batten/purlin |
| - Need of screws | 6 pcs/m ² |

3.8. Special areas. Check for installation instructions regarding flashings at 2.8 – 2.13

Maintenance of coated sheets

Check the coating once a year, preferably in spring. Remove all loose dirt from the roof and wash the roof with mild alkaline detergent. If the coating has been damaged or has peeled off, remove all loose coating material. Remove any rust or other impurities by gently scrubbing the stain with a steel brush or scraper. Repaint with a special paint developed by steel and paint manufacturers. Leading paint manufacturers will help you choose the right product.

A 7-POINT OBSERVATION LIST FOR YOUR ANNUAL CHECK-UP

CHECK THESE:

ACTION:

1. Paint, chalking, changes in colour, breaches at overlaps.

Assess which of the following are Necessary: washing, cleaning, treating corrosion at edges, repainting.

2. The gutters. Blocked gutters may cause corrosion and let water into the structures.

Clean the gutters of leaves and needles.

3. The sheets must be clean as wet leaves and needles will cause corrosion.

Clean the sheets with a soft brush or hose from the top down. Mild detergents may be used.

4. Any damage to the colour coat and dents.

Repaint locally or all over. Replace damaged sheets where needed.

5. Are there loose objects on the roof (bits of metal, screws)? They cause corrosion.

Remove any loose objects and use repair paint on any scratches.

6. Badly installed fastenings. They may cause leakage.

Replace all badly installed fastenings. If screw taps are damaged or do not screw tightly, use a thicker screw.

7. Any signs of corrosion at cut edges.

Remove loose paint and rust. First paint with primer colour and then with repair paint.

(Table 4)

Basic rules for installing Weckman roof sheeting on old roofs:

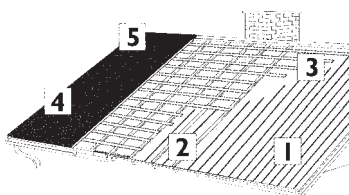

Old profiled roofing

1. Leave the old sheet profiles there.
2. Nail battens (thickness of the profiled sheet (min. 32 mm) on the roof trusses.
3. Install new roof boards as needed for roofing.
4. Fasten new sheets to the roof boards.
5. Fasten all fillings and flashings.

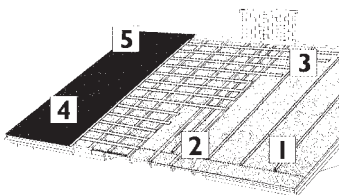

Old roofs with triangle battens

1. Leave the old triangle roofing in its place.
2. Nail battens at least as high in height as the triangle battens on the roof trusses.
3. Install new roof boards as needed for roofing.
4. Fasten new sheets on the roof boards.
5. Fasten all fillings and flashings.

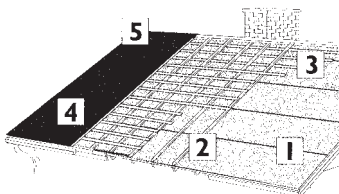

Plain felt covering

1. Leave the old roofing in its place.
2. Nail new low battens (min. 32 x 50 mm) on the roof trusses in a vertical position.
3. Install new roof boards as needed for roofing.
4. Fasten new sheets on the roof boards.
5. Fasten all fillings and flashings.

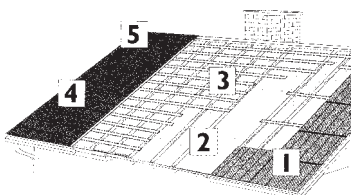

Old asbestos roofing felt

1. Take off the old asbestos roofing felt together with the roof boards. Install a new underlay if it is missing.
2. Nail vertical battens (min. 32 x 50 mm) at the roof trusses.
3. Install new roof boards as needed for roofing.
4. Fasten new sheets on the roof boards.
5. Fasten all fillings and flashings.

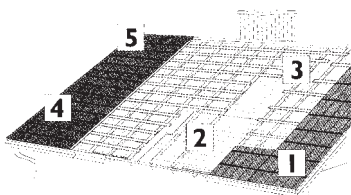

Old tile roofs

1. Remove old tiles and roof boards. Install a new underlay if it is missing.
2. Nail vertical battens (min. 32 x 50 mm) at the roof trusses.
3. Install new roof boards as needed for roofing.
4. Install new sheets on the roof boards.
5. Fasten all fillings and flashings.

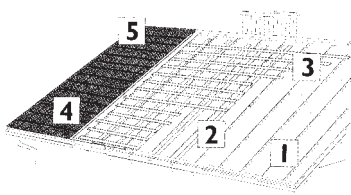

Old pointed joint roofs

1. Leave the old pointed joint roof there.
2. Nail battens at least as high in height as the pointed joints (min. 22 mm) in vertical direction on the roof trusses.
3. Install new roof boards as needed for roofing.
4. Fasten new sheets on the roof boards.
5. Fasten all fillings and flashings.

WECKMAN

Weckman Steel Oy

Härkäläntie 72
19110 Vierumäki
tel. 358 3 88 87100
fax 358 3 71 87839

www.weckmansteel.fi
export@weckmansteel.fi



for weatherproof
WECKMAN
roofs